

Full Metal Filler 200/300/400 – Datasheet

For high-outputs productions

1. Product presentation

- Each machine does one single capsule size.
- Only metallic plates and frame.
- Fill Capsule sizes 000, 00, 0, 1, 2, 3 and 4.
- No adjustment necessary.
- 200, 300 and 400 Capsules capacity.
- Very robust design.
- Easy to wash.

Filler capacity:

Capsule size:

Serial:

Full Metal 200:



Full Metal 300:



Full Metal Filler 200/300/400 – Datasheet

For high-outputs productions

Full Metal 400:



2. Safety information and disclaimer

All material should be cleaned before every use.

Many parts are heavy and might cause injury if mishandled or in case of fall.

Always work on a stable and flat surface, at a height that is comfortable to work while standing. Have sufficient free space around the machine that you are working with.

The filling being manual, results may vary depending on the user. Other factors can influence the results such as but not limited to: type of power, number of tamps, filling weight, capsule size, vibration type and intensity. It is the responsibility of the user to make sure the prescribed dose is respected. Fetton International is not responsible for wrong dosing.

Illustrations, descriptions and specifications are not contractual and are subject to change without prior notice.

Fetton International sprl declines all liability in the event of improper use of its products.

Full Metal Filler 200/300/400 – Datasheet

For high-outputs productions

3. Technical data

3.1 Components list and Materials

Note: The Filler presented in the images below is the 200-size. The same names and principles apply for the 300- and 400-sizes.

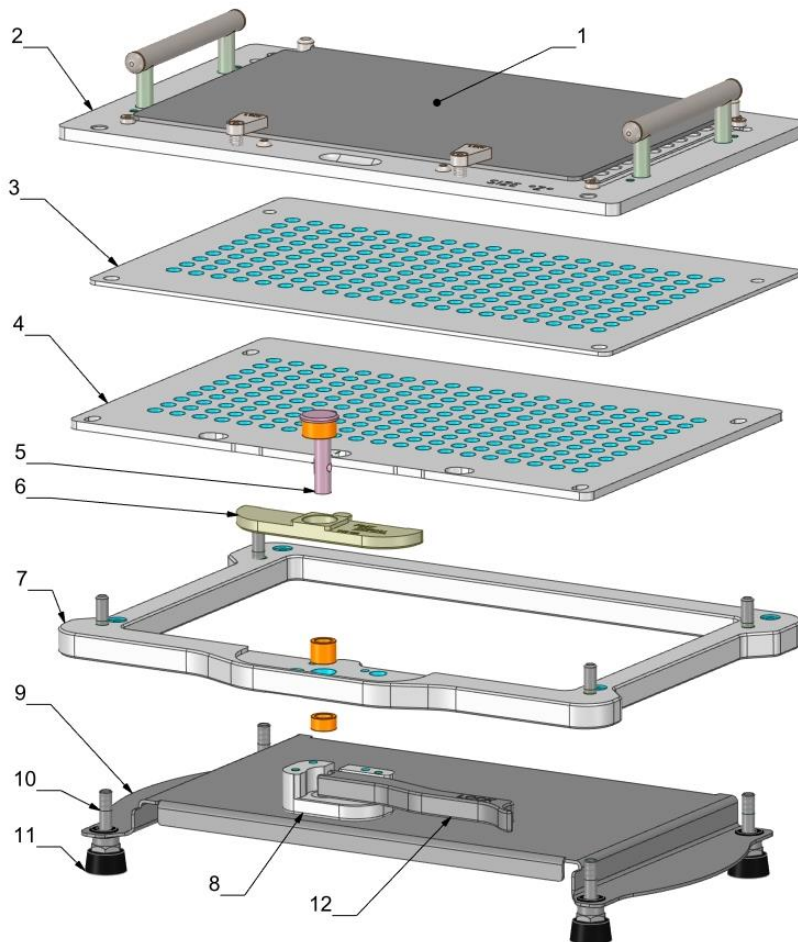

Item N°	Quantity	Name	Material
1	1	Lid	316 Stainless Steel
2	1	Aluminium Top plate 6mm	Durni-coat 520 Electroless Nickel
3	1	Filling Plate 2mm	316 Stainless Steel
4	1	Bottom Plate 4mm	316 Stainless Steel
5	1	Eccentric Pin	316 Stainless Steel
6	1	Pusher	316 Stainless Steel
7	1	Frame	316 Stainless Steel
8	1	Bloc pusher	316 Stainless Steel
9	1	Base Plate	316 Stainless Steel
10	4	Foot	304 Stainless Steel
11	4	Foot	Rubber
12	1	Lever	316 Stainless Steel

Full Metal Filler 200/300/400 – Datasheet

For high-outputs productions

3.2 Full Metal 200

Number of Capsules	200
Capsules Sizes options	000-00-0-1-2-3-4-5
Weight	5,8kg

Dimensions:

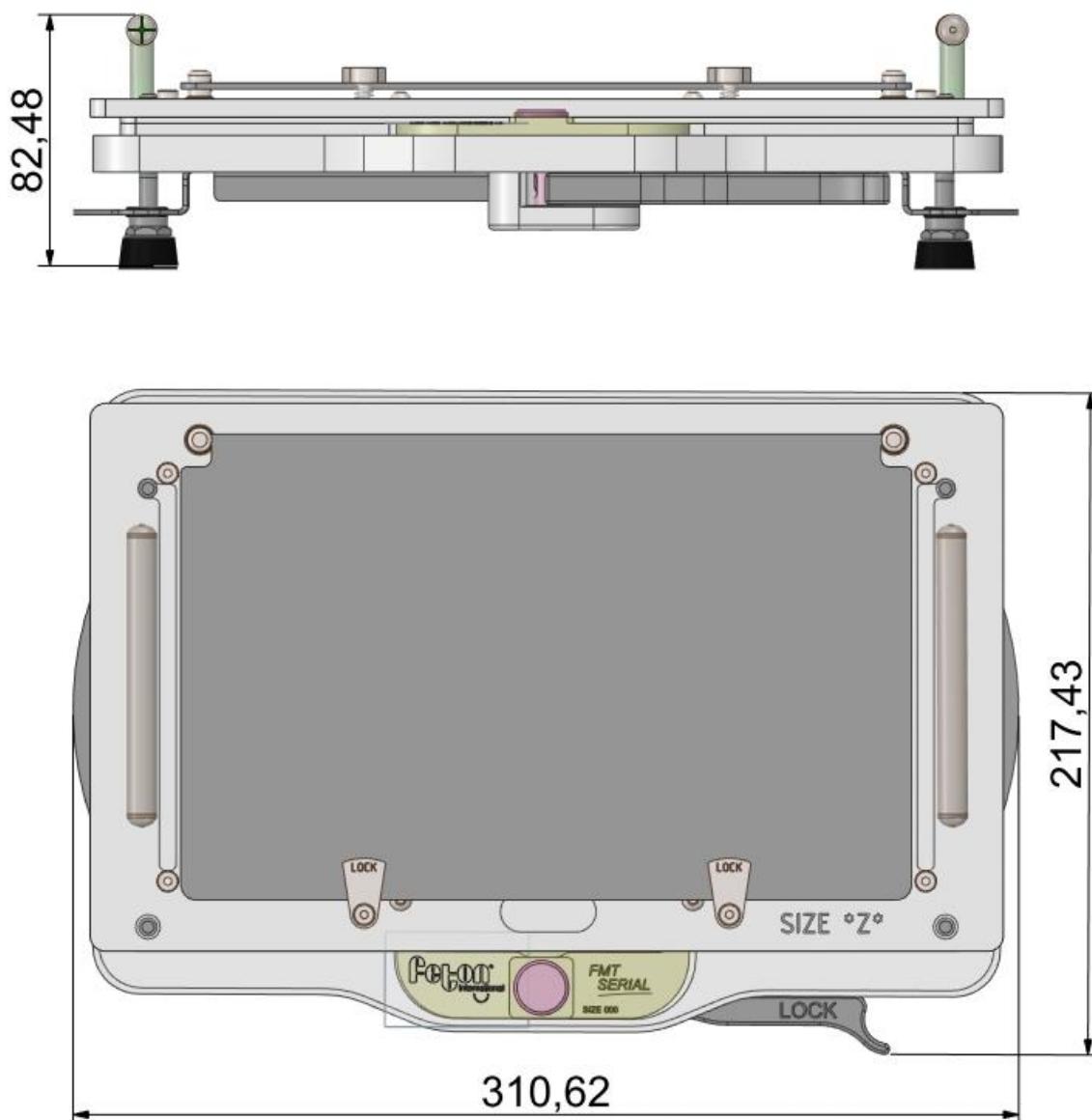

Full Metal Filler 200/300/400 – Datasheet

For high-outputs productions

3.3 Full Metal 300

Number of Capsules	300
Capsules Sizes options	00-0-1-2-3-4
Weight	7,8kg

Dimensions:

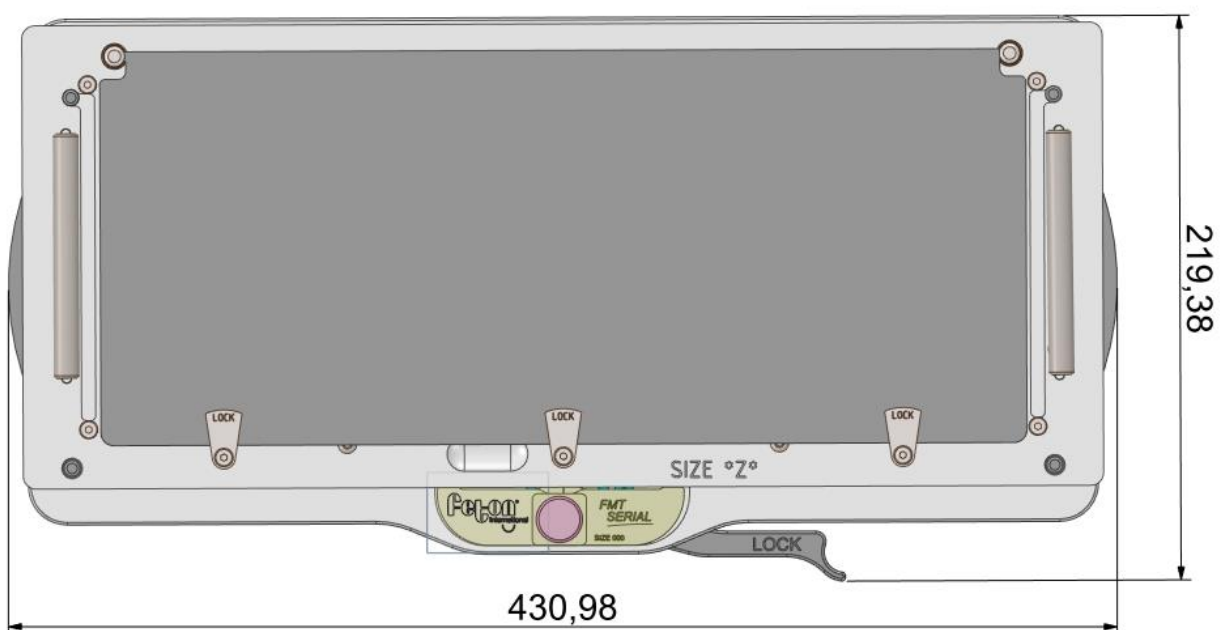
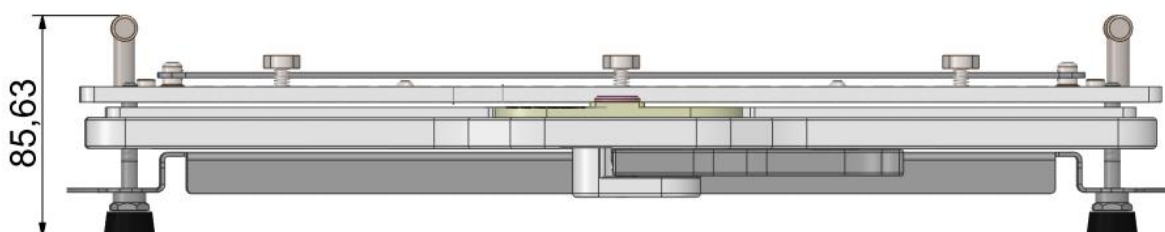

Full Metal Filler 200/300/400 – Datasheet

For high-outputs productions

3.4 Full Metal 400

Number of Capsules	400
Capsules Sizes options	00-0-1-2-3-4
Weight	9,8kg

Dimensions:

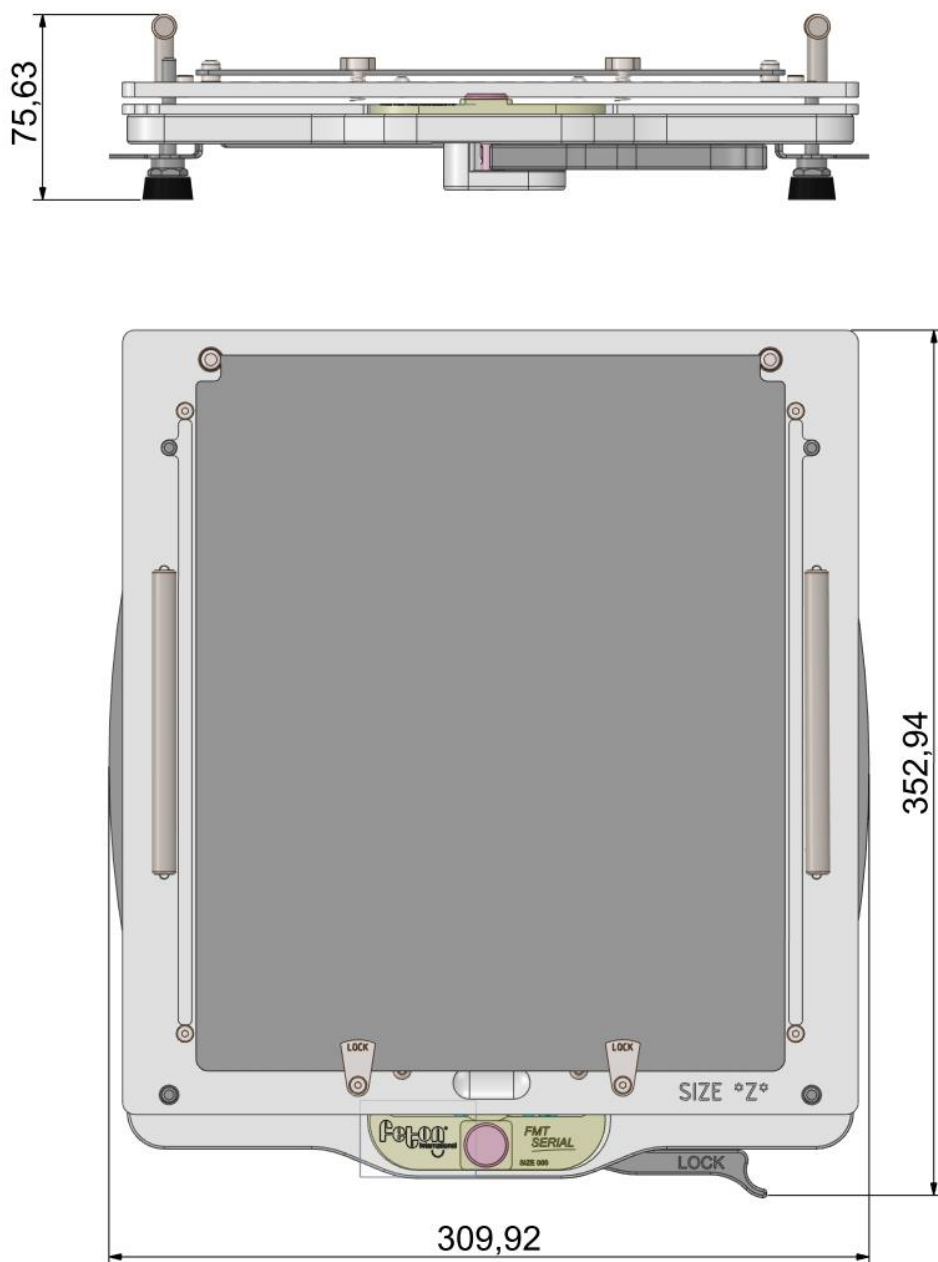

Full Metal Filler 200/300/400 – Datasheet

For high-outputs productions

4. How to use

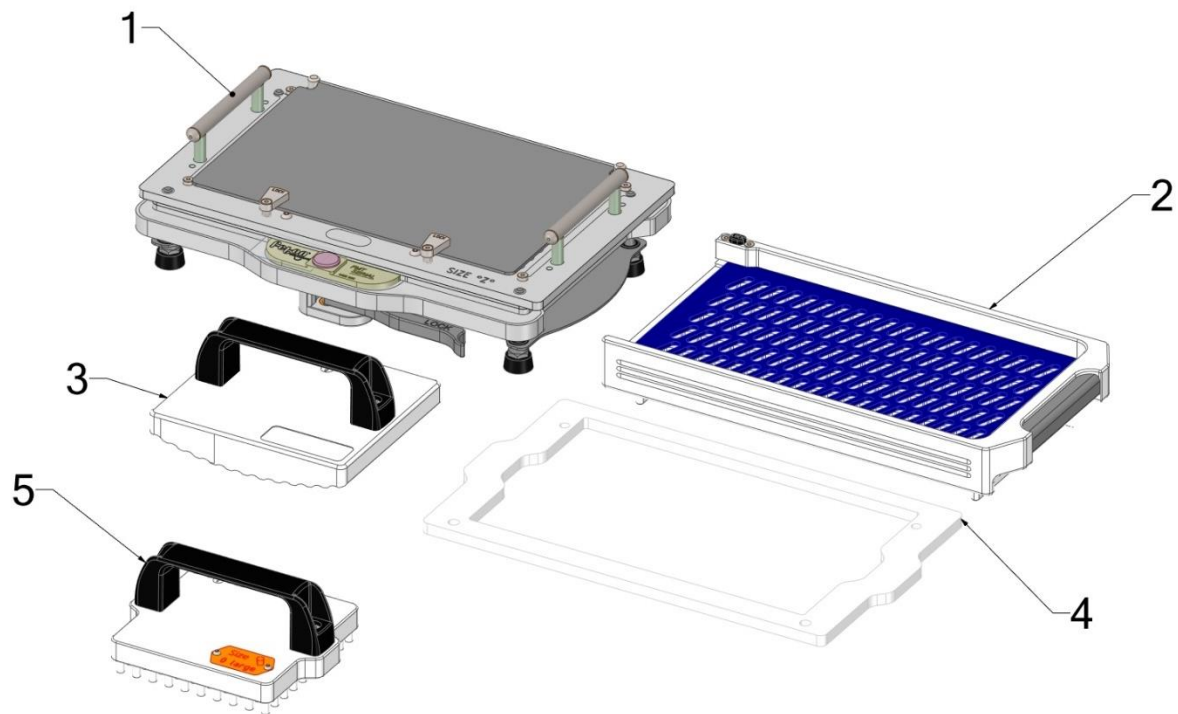

Item N°	Quantity	Name	Material
1	1	Capsule Filler	See 3.1
2	1	Capsule Loader (optional)*	POM and PMMA
3	1	Serial Closer (optional)*	POM
4	1	Powder Stop	PMMA
5	1	Tamper (optional)*	POM

NOTE : Operate your capsule filler at least one time without filling the capsules (steps 3-4-5-8) at the start of every preparation. This will allow you to check that everything is working correctly.

See table below for visual instructions.

1. Prepare your material. Install the plates in this order: Bottom Plate, Filling Plate, Top Plate.
2. Load the Capsules. Please refer to the Loader datasheet for detailed instructions.
3. Pull the Lever to lock the Capsules' bodies.

Full Metal Filler 200/300/400 – Datasheet

For high-outputs productions

4. Pull the Top Plate upwards, starting from the back side for easier separation. Push with your palms on the Handles and pull with the fingers on the Top Plate.
5. Release the Lever. If needed, push on the Capsules's bodies so that they are flush with the Filling Plate.
6. Fill the Capsules. Use of a Powder Stop is optional.
7. If needed, you can use a Tamper to push the powder into the Capsules to be able to fill a higher volume.
8. Place the Top Plate. Pull the Base Plate to push the Capsules' bodies into the Capsules' heads. The capsules are now "pre-closed".
9. Take the Top Plate and turn it upside down on your table. If you have a Serial Closer, use it to close the Capsules in two, three or four motions (depending on if you have a 200, 300 or 400). If you do not have a Serial Closer, close the capsules by hand.
10. Your Capsules are now ready.

1

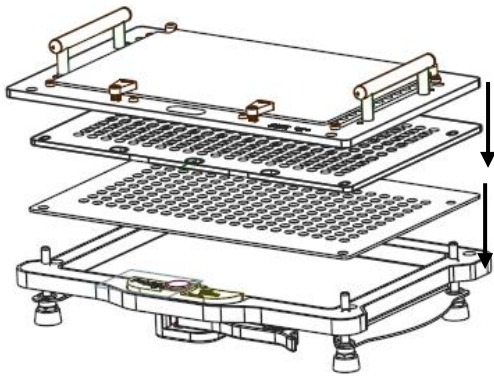

2

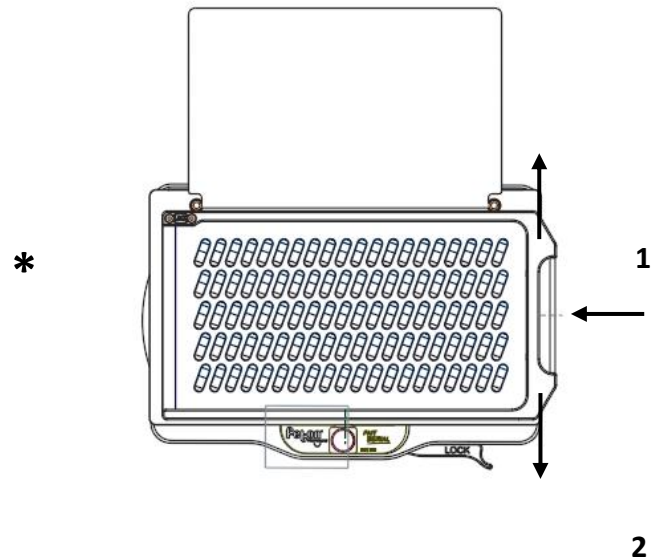

3

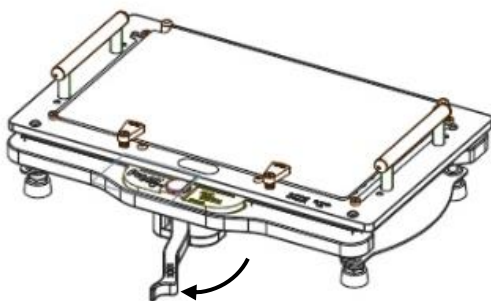

4

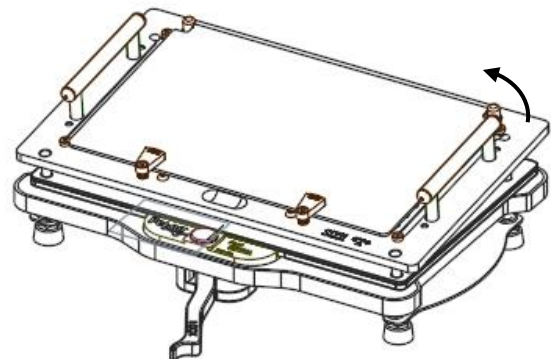

Full Metal Filler 200/300/400 – Datasheet

For high-outputs productions

5

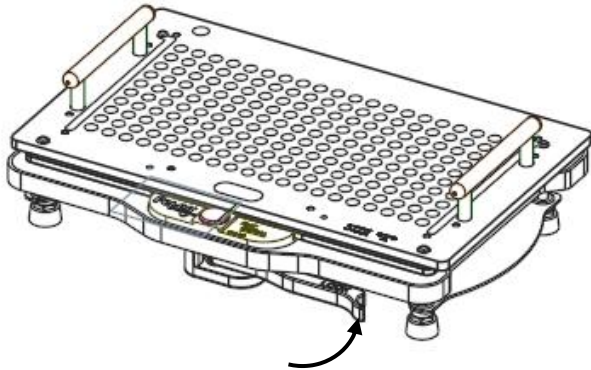

6

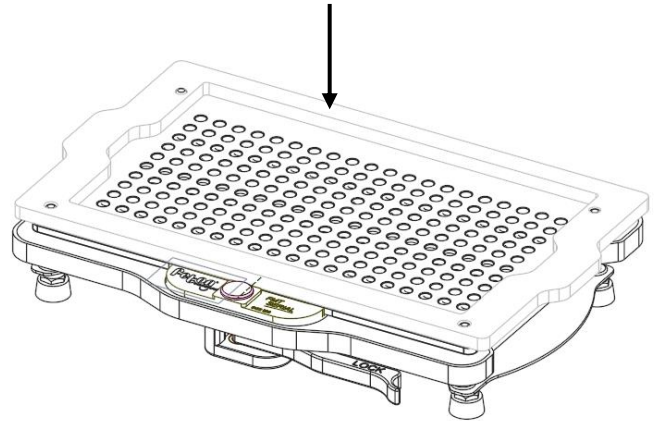

7

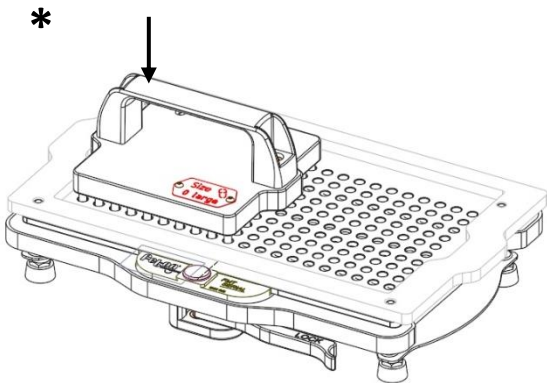

8

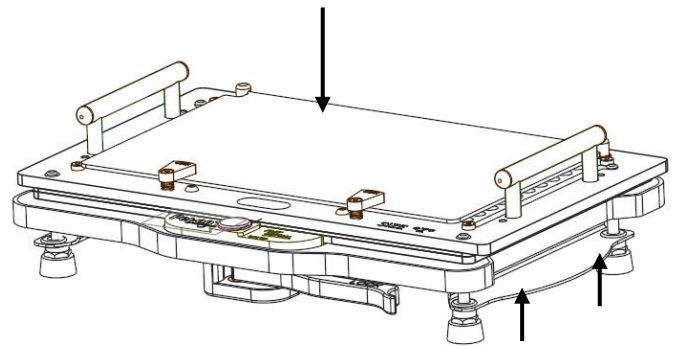

9

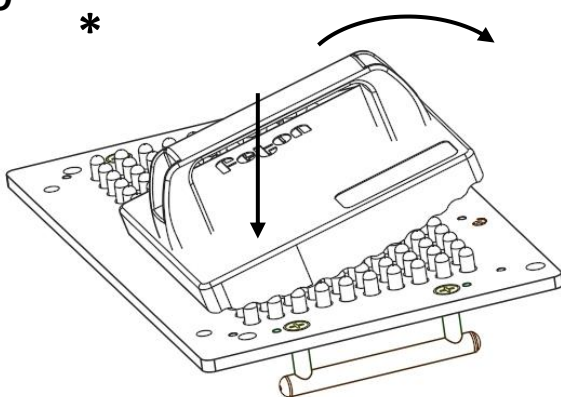

10

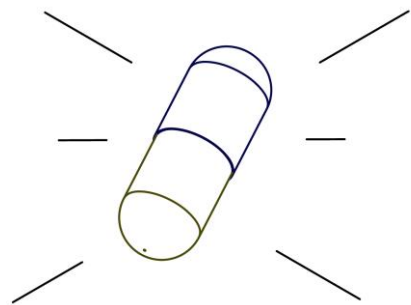

* Optional accessory

Full Metal Filler 200/300/400 – Datasheet

For high-outputs productions

5. How to wash

It is important to wash the parts in contact with the capsules or the powder thoroughly between each use to avoid contamination. Washing can be done by hand, in a dishwasher or in an autoclave. If done by hand, use warm water and soap.

Use a temperature of up to 110°C / 230°F for all the metallic parts.

Use a temperature of up to 40°C / 104°F for all the plastic parts.

If you have difficulties washing the inside of holes on the plates, use a brush:

